



## **SRE-1550 Electra-Ride II Stairway Elevator** **Technical Specifications**

Rev: 08-01-2008  
ILS-00812

**MODEL NUMBER:** SRE-1550 & SRE-1550C  
**U.S. F.D.A. CLASSIFICATION:** Class II,  
**CLASSIFICATION NUMBER:** 890.5150

**PERFORMANCE STANDARDS:** USA Food & Drug Administration: None  
ANSI/ASME: A18.1-2005 Safety Standards for Platform Lifts and Stairway Chairlifts  
ANSI/ASME: A17.1-1996 Commercial (PART XX) &  
Private Residence Inclined Lifts (PART XXI)  
CSA/C-US Listed: File Number 208135

**RATED LOAD:** 350 lbs maximum

**NUMBER OF PASSENGERS:** 1

**POWER SOURCE:** 24 Volt DC comprised of 2ea 7amp/hr 12 volt sealed maintenance-free lead acid batteries. On/Off power switch to prevent battery drain over lengthy storage periods.

**CHARGER:** 110 Volt AC 1.5 Amp, 24 Volt DC 2 Amp continuous monitoring, full primary cut off.

**DRIVE:** 24 Volt DC motor, 2 pole rated 1.02 hp intermittent duty (2hr cont.) limited at current setting, no load speed 3800 rpm

**GEAR BOX:** 20:1 Right angle self locking worm drive

**INTERMEDIATE REDUCTION:** (Motor & Gearbox) "J" style poly-V belt with dual 3 V wide belts, 4: 1 reduction.

**FINAL DRIVE:** 8dp rack welded to inside of rail with a spur gear on the gearbox output shaft.

**MOTOR CONTROLLER:** Custom 24 Volt DC PWM controller with acceleration ramping.

**BRAKING:** dynamic motor braking through the motor controller and self locking worm gear box.

**Bruno Independent Living Aids, Inc., 1780 Executive Drive, P.O. Box 84, Oconomowoc, WI 53066**  
**Phone (800) 882-8183 Fax (262) 953-5501**

Any reproduction or other use of these materials without written permission of Bruno Independent Living Aids, Inc. is expressly prohibited. Bruno Independent Living Aids, Inc. reserves the right to modify or make changes to these specifications at any time without notice.

**REMOTE CONTROL:** Infra-red wireless "CALL/SEND" control. Momentary switching requires a user to continuously hold button to control unit.

**STANDARD CONTROL:** 3 position, momentary rocker switch requiring user to continuously hold rocker switch to control unit, switch mounted under armrest. Optional "keyed" control.

**MOUNT:** Either side of stairway, the unit is easily installed on either side of the staircase.

**SUPPORTS:** Clamps anchored to stair tread, normal rail position is 1" above step nose. Number of clamps dependent on the length of rail. Optional height adjustable clamps available.

**ANGLE:** Adjustable from 0 to 45 degrees standard, specials to 50 degrees.

**SPEED:** User adjustable with a maximum of 32 feet per minute, actual loaded top speed 28 feet per minute.

**LENGTH OF TRACK:** 16 foot & 20 foot standard, Dealer to cut to fit the actual length of the stair, see application guide. Custom lengths to 50 foot.

**TRACK CONSTRUCTION:** 11 ga. mild steel roll formed to shape, gear rack welded to rail. Joint plates with (2) welded on side clamp blocks at each rail joint.

**FOOTREST:** Folding.

**SEAT OPTIONS:**

**Standard Seat:** Padded, Folding & Swivels with stops at 45 degree intervals (+/- 90 degrees max.) Four position seat height adjustment. Arm rests are fixed to seat bottom, tilting up towards seat back for smaller profile when not in use. Arms swing out for easier transfers.

**Large Seat with Fixed Arms (1540 Style):** Padded, Folding & Swivels with stops at 45 degree intervals (+/- 90 degrees max.) Four position seat height adjustment. Arm rests are fixed to seat bottom, tilting up towards seat back for smaller profile when not in use.

**SAFETY EQUIPMENT:** 1) Seat swivel switch allows operation only when chair is in center position.

2) Footrest safety switches

3) Seat belt

4) Carriage safety switches

5) Charging Light (amber) at each end of rail

6) 25 amp manual reset breaker on the motor control circuit

7) Final end stop bumper at each end of the rail

8) Final limit switch

9) Full diagnostic integrated motor control/interconnect circuit board

10) Optional overspeed safety brake

**Bruno Independent Living Aids, Inc., 1780 Executive Drive, P.O. Box 84, Oconomowoc, WI 53066  
Phone (800) 882-8183 Fax (262) 953-5501**

Any reproduction or other use of these materials without written permission of Bruno Independent Living Aids, Inc. is expressly prohibited. Bruno Independent Living Aids, Inc. reserves the right to modify or make changes to these specifications at any time without notice.

**POWER OUTAGE:** Unit will have 8 (minimum) to 20 round trips on battery charge (variance caused by angle, length of run, ambient temperature and rider weight). Batteries will last between 28 and 36 hours after the power is disconnected.

**WEIGHT OF UNIT:** 300 lbs. without rider in a typical 16 foot installation

**TESTING PERFORMED:**

- 1) Life cycle of 36,000+ cycles with full rated load at 45 degrees on a 20' rail. Gearbox, rail, and components had minimal wear. Estimated yearly heavy use is 1200 cycles. This test performed at manufacturer's location.
- 2) Battery charger UL tested and listed to standard UL1012.
- 3) The self locking gear box was statically tested with 2800 lbs (7X rated load) on a 45 degree rail for 15 minutes with no carriage movement. This test was performed at the manufacturer's location.
- 4) Repetitive tests were run to determine power outage cycling.
- 5) Electrical discharge to ground testing performed for FDA 510(k).

**COMMERCIAL PACKAGE:** Keyed rocker switch on chair, keyed remote call/send controls, and overspeed safety brake.

**Bruno Independent Living Aids, Inc., 1780 Executive Drive, P.O. Box 84, Oconomowoc, WI 53066  
Phone (800) 882-8183 Fax (262) 953-5501**

Any reproduction or other use of these materials without written permission of Bruno Independent Living Aids, Inc. is expressly prohibited. Bruno Independent Living Aids, Inc. reserves the right to modify or make changes to these specifications at any time without notice.

**TECHNICAL DATA/SPECIFICATIONS**

MODEL: SRE-1550 Electro Ride II  
 RATED LOAD: 350 LBS, ONE PASSENGER  
 POWER SOURCE: 24 VOLT DC COMPRISED OF (2) 7 AMP/HR 12 VOLT SEALED BATTERIES.  
 110 VOLT AC 1.5 AMP, 24 VOLT DC 3 AMP CONTINUOUS MONITORING CHARGER.  
 DRIVE: 24 VOLT DC MOTOR, 2 POLE RATED 1.02 HP NO LOAD SPEED OF 3800 RPM.  
 20:1 RIGHT ANGLE SELF-LOCKING WORM DRIVE GEAR BOX WITH 4:1 INTERMEDIATE REDUCTION USING DUAL 3 V WIDE BELTS.  
 FINAL DRIVE: RACK & PINION - 8DP RACK WELDED TO THE RAIL WITH A SPUR GEAR ON THE GEARBOX SHAFT.  
 BRAKING: DYNAMIC MOTOR BRAKING THROUGH THE MOTOR CONTROLLER AND SELF LOCKING WORM GEAR.  
 CONTROLS: CONTINUOUS PRESSURE ROCKER SWITCH LOCATED ON ARMREST AND WALL MOUNTED CALL/SEND CONTROLS LOCATED AT BOTH TOP & BOTTOM LANDINGS.  
 ANGLES: 0 TO 45 DEGREES (Specials up to 50 Degrees)  
 SPEED: 35 FEET PER MINUTE UNLOADED 28 FEET PER MINUTE WITH RATED LOAD (SPEED SETTINGS ARE ADJUSTABLE)  
 FINAL LIMIT SWITCH STANDARD  
 OPTIONS:  
 ----- COMMERCIAL PACKAGE INCLUDES OVERSPEED SAFETY BRAKE, KEYED CALL/SEND CONTROLS, & KEYED CONTROLS ON CHAIR

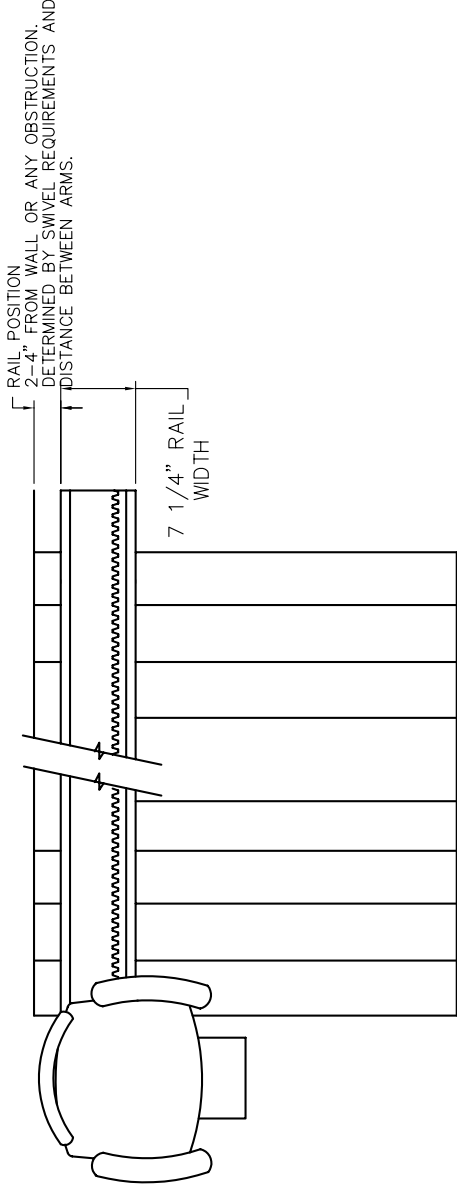

TOP VIEW

DISTANCE BETWEEN ARMS IS ADJUSTABLE TO 20 INCHES.

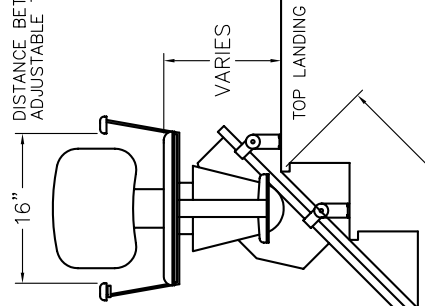

ELEVATION VIEW

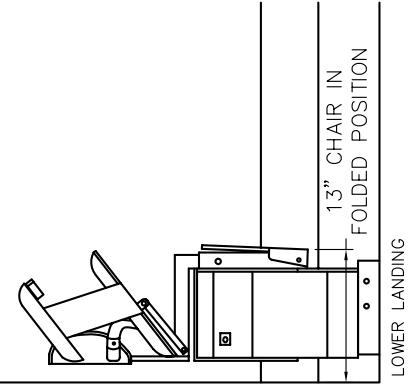

SIDE VIEWS

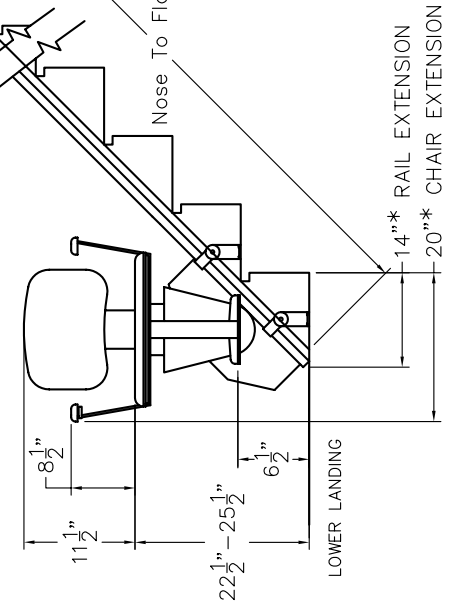

\* LOWER LANDING EXTENSION DIMENSION ARE BASED ON 40 DEGREE RAIL SLOPE AND 8" 1ST RISER HEIGHT. DIMENSIONS WILL VARY BASED ON SLOPE AND RISER HEIGHT.



P.O. Box 84  
 Oconomowoc, WI 53066  
 Tel 800-882-8183  
 Fax 262-953-5501  
<http://www.bruno.com/>

rev: 04/15/2005 ILS-00820  
 Page 1 of 2

ALL DIMENSIONS SHOWN ARE BASED ON A WALL TO RAIL DIMENSION OF 3".

